

696+ 2-DK

INCLINED SCREEN



Screen Size:	6100mm x 1700mm (20' x 5' 7")	
Net Engine Power:	Tier 3/Stage IIIA:	Caterpillar C4.4 90kW (121hp)
	Tier 4/Stage IV:	Caterpillar C4.4 93kW (125hp)
	Stage V:	Caterpillar C4.4 102kW (137hp)
Portability:	Tracked	
Operating Weight:	33,800kg (74,550lbs) (With tipping grid)	

STRONG **HERITAGE**, STRONG **FUTURE**

 **FINLAY**[®]
A TEREX BRAND

SPECIFICATION

HOPPER / FEEDER

Hopper Capacity: 8m³ (10.5yd³)

Feed height: 2.5m (8' 2")

Feed in width: 4.2m (13' 9") (grid wing plates)

Grid aperture: 100mm (4")

Drive: variable & high torque w/g. box

Beltfeeder belt width: 1.2m (48")

Belt Spec: Plain EP500/3.5+1.5

Speed: variable, 0 - 16 mpm (0 - 53' per min)

Wide mouth opening

MAIN CONVEYOR

Drive: Hydraulic drive via high torque 630cc motor

Belt width: 1.2m (48")

Belt spec: EP400 3 Ply 3+1.5

Hydraulic slide

Hydraulic discharge height adjustment

Belt Speed: 92 mpm (302' per min)

Steel skirted full length of conveyor

SCREEN BOX

All decks: 6.1m x 1.7m (20' x 5' 7")

Wedge side tensions top deck mesh

End tensioned bottom deck

Hydraulic end tensioned bottom deck mesh

Drive: Hydraulic heavy duty 2-Bearing

Hydraulic Folding Catwalks

Screen Angle: 18° - 32°, hydraulic adjust

Screen stroke standard: 7mm (9/32")

Screen speed: 1050 rpm

Abrasion resistant material impact plate

Spreader plate

Galvanised access catwalks on both sides and top end of screen

Total screening area: 20.74m² (223ft²)

SIDE CONVEYORS

Drive: Hydraulic variable speed drive via high torque 400cc motor

Belt width: 800mm (32")

Belt spec: Chevron EP315/3+1.5 (15mm Rib)

Working Angle: 22°

SIDE CONVEYORS

Speed: Variable speed, 0 - 90 mpm (0-295' per min)

Hydraulic Folding

Discharge Height: 5.1m (16' 9")

Stockpile capacity: 228m³ (298yd³)

FINES CONVEYOR

Drive: Hydraulic variable speed drive via high torque 800cc motor

Belt width: 1.2m (48")

Belt spec: Plain, EP400 / 3 Ply 3+1.5

Working Angle: Variable 27.5° (Max)

Rosta scraper on head drum

Speed: 125mpm (410' per min)

Standard Discharge Height: 5.5m (18' 1")

Stockpile capacity: 285m³ (373yd³)

POWERUNIT AND HYDRAULICS

Tier 3 / Stage IIIA: Caterpillar C4.4

Engine Power: 90kW (121hp)

Engine Speed: 1800 rpm

Tier 4F / Stage IV: Caterpillar C4.4

Engine Power: 93kW (125hp)

Engine Speed: 1800 rpm

Stage V: Caterpillar C4.4

Engine Power: 102kW (137hp)

Engine Speed: 1800 rpm

Pump 1: Triple 63cc/rev, 41cc/rev, 41cc/rev

The first section drives the Fines/Tail conveyor and screen motor only

The second section drives either the main conveyor (and optionally the vibrating grid if option is selected) or drives the left track motor

The third section drives either the feeder conveyor or drives the right track motor

Pump 2: Triple 23cc/rev, 23cc/rev, 14cc/rev,

The first section drives either the oversize conveyor or drives the auxiliary ram circuit

The second section drives only the midsize conveyor

The third section drives the tipping rams for the tipping grid (or vibrating grid if option is selected)

TANK CAPACITIES

Hydraulic Tank: 450 litres / 99 UK gal / 119 US gal

Fuel Tank: 336 litres / 74 UK gal / 88 US gal)

UNDERCARRIAGE

Shoe Width: 500mm (20")

Sprocket Centres: 4.2m (13' 8")

Speed: 0.8 km/h

Gradeability: 32.6°

Raking Angle: 9°

STANDARD FEATURES

ENGINE:

Tier 3 / Stage 3A Caterpillar C4.4 - 4 cylinder diesel engine developing 90kW (121hp) @ 1800rpm

Tier 4F / Stage IV - Caterpillar C4.4 - 4 cylinder diesel engine developing 93kW (125hp) @ 1800rpm

Stage V Caterpillar C4.4 - 4 cylinder diesel engine developing 102kW (137hp) @ 1800rpm

FEEDER:

Hopper Capacity: 8m³ (10.5yd³)

Hopper feed length: 4.25m (14ft)

Belt width: 1.2m (48") variable speed belt feeder

Remote control hydraulic tipping reject grid c/w grouser bars 4.25m x 100mm spacing (14' 0" x 4")

SCREENBOX:

6.1m x 1.7m (20' x 5'7") top and bottom deck screenbox

No mesh or speed harps included for any deck (but all mesh fitting parts included as standard)

Quick wedge tensioning - top deck

Hydraulic tensioning (bottom deck screen mesh)

MAIN CONVEYOR:

Belt Width: 1.2m (48") c/w skirting

Hydraulic raise of Main Conveyor head-section (For improved mesh access)

SIDE CONVEYORS:

Belt Width: 800mm (32") chevron on both side conveyors

FINES CONVEYOR:

Belt Width: 1.2m (48") plain belt

ELECTRICAL:

Emergency Stops

Control operation of tracks via hand-held set

T-Link Telemetry System fitted c/w 7 years data

GENERAL:

Safety guards in compliance with machinery directive

Low level central greasing

OPTIONAL EQUIPMENT

Dual Power - 2 x37kW IE3 electric motors c/w hydraulic gear pumps and electrical control panel allowing machine to run in either Diesel or Electric mode**

***"STD voltage supply: 380V - 440v @ 50Hz.(Contact the factory for availability, lead-time and if any local requirements are different from standard offering"

No grid but hopper dead plate

Double Deck Vibrating Grid

12' Tipping Grid

Top deck mesh

Bottom deck mesh/ speed harp

Anti Roll back plates for main conveyor 3Nr

Aluminium Rapid-Fit dust covers on main and fines belt

Dust suppression system on fines belt. Does not include water pump

Radio Remote control of tracks

Working lights on power unit & main conveyor

68 grade hydraulic oil

Option for 1nr dedicated Stockpiler Drive - Approx 60 Litres/min - Diesel only

Screenbox Rotation Reversal control

Special paint colour (if different from Finlay Orange RAL 2002). RAL must be specified on order

Over-size Conveyor

- ▶ Drive: Hydraulic variable speed drive via high torque 400cc motor
- ▶ Belt width: 800mm (32")
- ▶ Belt spec: Chevron EP315/3+1.5 (15mm Rib)
- ▶ Working Angle: 22°
- ▶ Speed: Variable speed, 0 - 90 mpm
- ▶ Discharge Height: 5.1m (16' 9")

Main conveyor

- ▶ Drive: Hydraulic drive via high torque 630cc motor
- ▶ Belt width: 1.2m (48")
- ▶ Belt spec: Plain EP400 3 Ply 3+1.5
- ▶ Hydraulic slide
- ▶ Belt Speed: 92 mpm (302' per min)
- ▶ Steel skirted full length of conveyor

Hopper / Feeder

- ▶ Hopper Capacity: 8m³ (10.5yd³)
- ▶ Feed height: 2.5m (8' 2")
- ▶ Feed in width: 4.2m (13' 9") (grid wing plates)
- ▶ Grid aperture: 100mm (4")
- ▶ Drive: variable & high torque w/g. box
- ▶ Beltfeeder belt width: 1.2m (48")
- ▶ Belt Spec: Plain EP500/3.5+1.5
- ▶ Speed: variable, 0 - 16 mpm (0 - 53' per min)
- ▶ Wide mouth opening

Fines conveyor

- ▶ Drive: Hydraulic variable speed drive via high torque 800cc motor
- ▶ Belt width: 1.2m (48")
- ▶ Belt spec: Plain, EP400 / 3 Ply 3+1.5
- ▶ Working Angle: Variable 27.5° (Max)
- ▶ Rosta scraper on head drum
- ▶ Speed: 125mpm (410' per min)
- ▶ Standard Discharge Height: 5.5m (18' 1")

Screen box

- ▶ All decks: 6.1m x 1.7m (20' x 5' 7")
- ▶ Wedge side tensioned Top Deck mesh
- ▶ End tensioned bottom deck
- ▶ Hydraulic end tensioned bottom deck mesh
- ▶ Drive: Hydraulic heavy duty 2-Bearing
- ▶ Hydraulic Folding Catwalks
- ▶ Screen Angle: 18° - 32°, hydraulic adjust
- ▶ Screen stroke standard: 7mm (9/32")
- ▶ Screen speed: 1050 rpm
- ▶ Abrasion resistant material impact plate
- ▶ Total screening area: 20.74m² (223ft²)

Power unit

- ▶ Tier 3 / Stage IIIA: Caterpillar C4.4
- ▶ Engine Power: 90kW (121hp)
- ▶ Engine Speed: 1800 rpm
- ▶ Tier 4F / Stage IV: Caterpillar C4.4
- ▶ Engine Power: 93kW (125hp)
- ▶ Engine Speed: 1800 rpm
- ▶ Stage V: Caterpillar C4.4
- ▶ Engine Power: 102kW (137hp)
- ▶ Engine Speed: 1800 rpm

Middle-grade Conveyor

- ▶ Drive: Hydraulic variable speed drive via high torque 400cc motor
- ▶ Belt width: 800mm (32")
- ▶ Belt spec: Chevron EP315/3+1.5 (15mm Rib)
- ▶ Working Angle: 22°
- ▶ Speed: Variable speed, 0 - 90 mpm
- ▶ Discharge Height: 5.1m (16' 9")

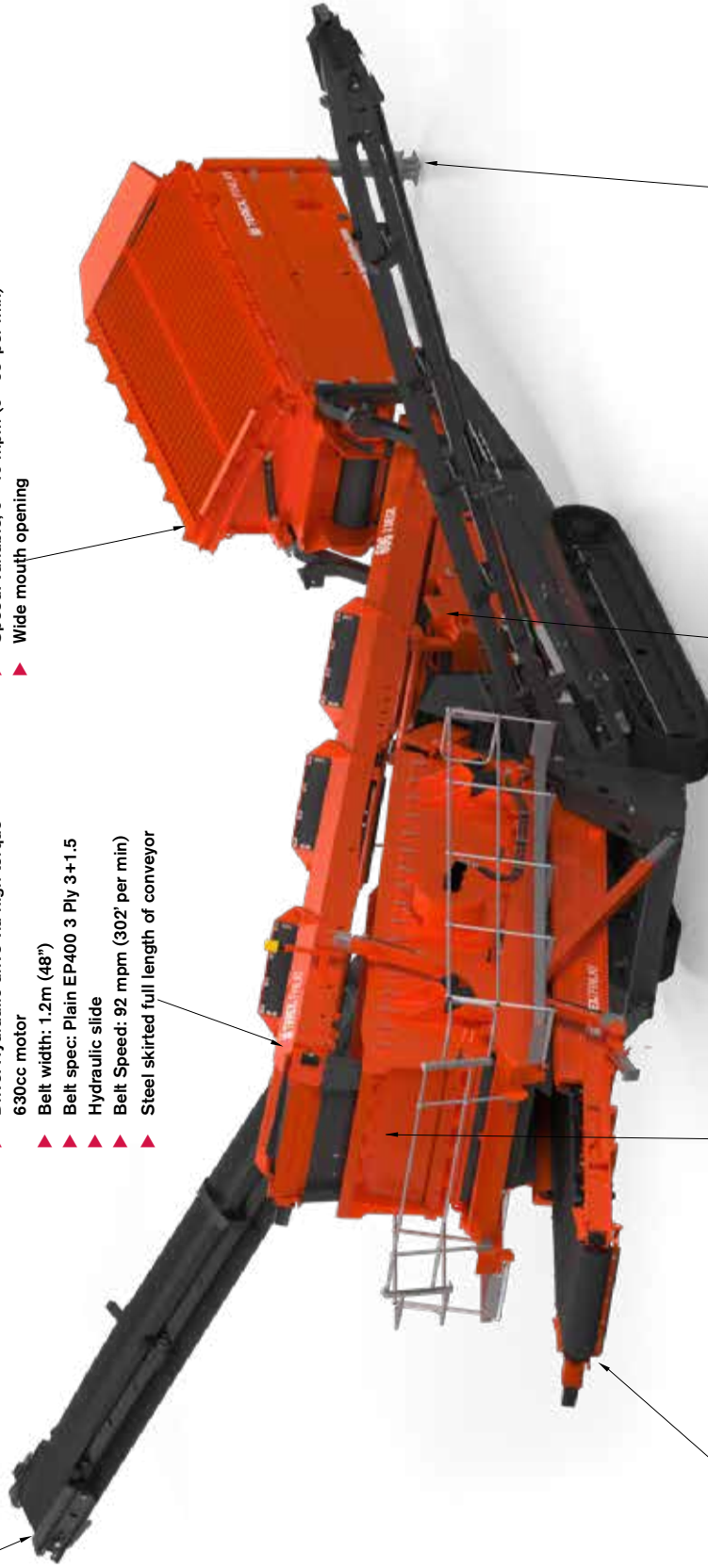

TRANSPORT DIMENSIONS



WORKING DIMENSIONS

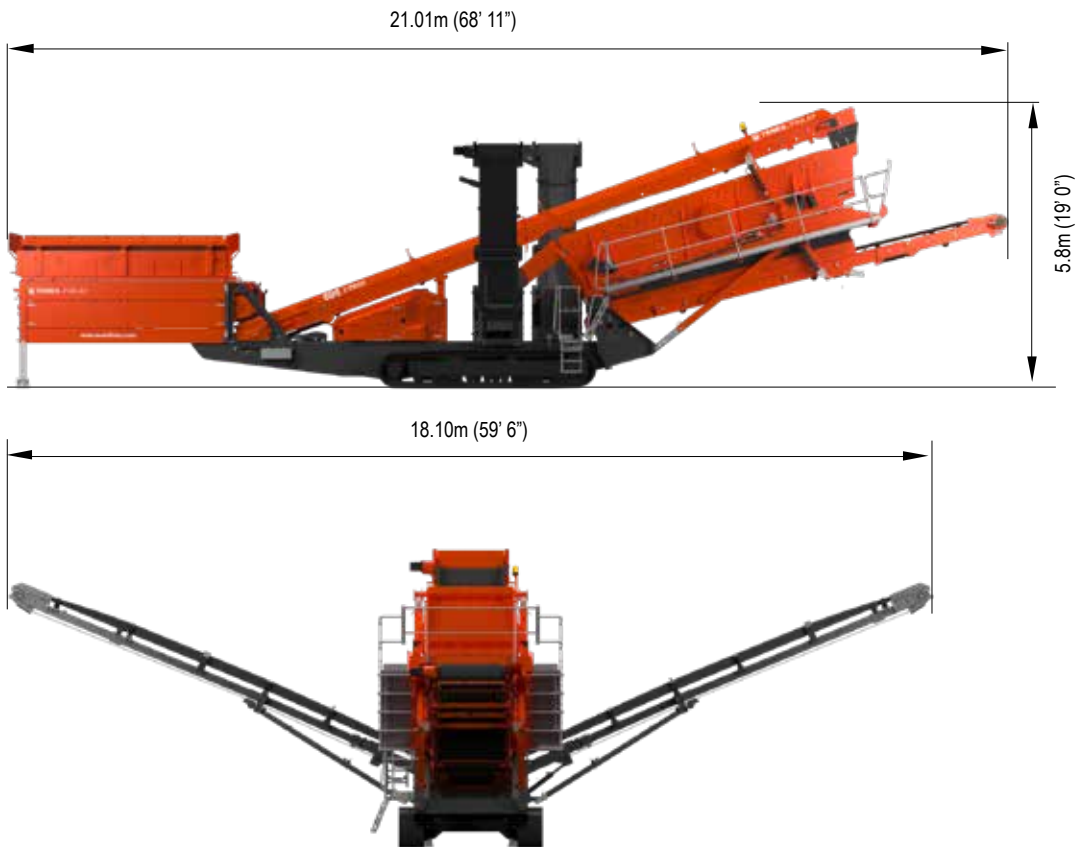

MACHINE WEIGHT: 33,800kg (74,550lbs)
with tipping grid

37,300kg (82,250lbs)
double deck vibrating grid

For further information on specific machine weight configurations please consult Terex Finlay

